

MCRT[®] 48000P & 49000P Non-Contact Horsepower/kW-h Meters

Power Ranges: 5.95 to 76,160 hp (4.44 to 56,800 kW)
Torque Ranges: 25 to 4,000,000 lbf-in (2.8 to 452,000 N-m)

- **0.08% Accuracy**
- **Outputs Analogs of Shaft Power, Torque, Speed and Energy (optional)**
- **Engineering Unit Output Via RS232C Port; PC Interface Software Furnished**
- **Automatic Zero and Span, No Manual Adjustments**
- **Bidirectional Operation Valid to Zero Speed**



Requires A Single, Unregulated DC Supply; Has SS Shaft, Is Splashproof & Corrosion Resistant

200% and 400% Overload Ratings
14 Bit Accurate Digital Signal Processing
Hardened to EMI From Adjustable Speed Drives
Remote, Bidirectional NIST Traceable Calibration*

*NIST traceable calibration performed in our accredited laboratory (NVLAP Lab Code 200487-0). For details visit www.himmelstein.com or follow the accreditation link at www.nist.gov.

MCRT[®] Horsepower/kW-h Meters measure and output **shaft power, energy, torque and speed; energy is an option. Manual adjustments and noisy pots are eliminated.** Null, scaling and units of measure are stored in non-volatile memory. Digital computation of power and energy, is errorless. Fifty-one common units of measure are supported. Eleven selectable Bessel filters *avoid delay distortion and overshoot* and assure optimal response. Input power is a single, unregulated dc supply that is reverse polarity protected.

If you re-calibrate, previous calibration values are archived. Pin strapping and serial commands enable simultaneous, traceable* power/energy/torque/speed calibrations, remote zeroing and energy reset. Password protection may be invoked if needed. Included software interfaces with Windows-based PC's. It displays and plots real time data, and does time and X-Y plots. Use it to select 5V or 10V analog outputs, signal filter cutoff frequencies, scaling, units of measure and/or to control measurements.

S. HIMMELSTEIN AND COMPANY

2490Pembroke Avenue, Hoffman Estates, Illinois 60169 • Tel: 847/843-3300 • Fax: 847/843-8488

Both shaft end and flanged models are manufactured with 200% (MCRT® 48000P) and 400% (MCRT® 49000P) overload ratings. Shaft end horsepower/kW-h meters are the choice for most applications. They are less costly and can be floated or foot mounted; a foot mount option is available on shaft end units. A flanged horsepower/kW-h meter must be installed as a floating

shaft. Flanged meters are much shorter than shaft end units. Thus, flanged models are used when axial space is limited. Flanged models handle large* axial loads without special mounting considerations. They are often used in marine or vehicular drives, to support the weight and thrust of a mixers' impeller, and in other similar circumstances.

* generally a thrust in pounds equal to the full scale torque rating in pound-inches.

Common Specifications	Code N Performance (available on all ranges)	Code C Performance (available on ranges ≥10 Hp and ≥50 lbf-in)
Torque and Speed Ranges	Factory Set @ Transducer Full Scale Torque and Maximum Speed. Field Resettable to any lower value.	
Power and Energy Ranges – See Note 1	Power is the Product of Transducer Full Scale Torque, Speed Range and Scaling Constant; Energy is ∫Power dt	
Units of Measure	Default units are hp, kW-h, lbf-in, rpm with Energy option; kW-h is omitted without it. Any of 51 (33 without Energy Option) supported units may be specified or, user entered with a PC and furnished software. See back cover for listing.	
Power, Energy, and Torque Nonlinearity²	≤ ±0.1 (End Point, % of F.S.)	≤ ±0.05 (End Point, % of F.S.)
Power, Energy, and Torque Hysteresis²	≤ ±0.1 (End Point, % of F.S.)	≤ ±0.05 (End Point, % of F.S.)
Power, Energy, and Torque Nonrepeatability²	≤ ±0.05 (% of F.S.)	≤ ±0.03 (% of F.S.)
Power, Energy, and Torque Accuracy²	≤ ±0.13 (% of F.S.)	≤ ±0.08 (% of F.S.)
Speed Nonlinearity & Hysteresis	≤ ±0.01% Each (End Point, % of F.S.)	
Speed Nonrepeatability	≤ ±0.005 (% of F.S.)	
Speed Accuracy	≤ ±0.06 (% of F.S.)	
Power Calibration Accuracy (% of F.S. @ 75 deg.)	≤ ±0.05	≤ ±0.03
Speed Calibration Accuracy (% of F.S. @ 75 deg. F.)	≤ ±0.005	
Torque Calibration Accuracy (% of F.S. @ 75 deg. F.)	≤ ±0.05	≤ ±0.03
Calibration Enable	Strap the CW (or CCW) Cal Line to Common for simultaneous CW (or CCW) Power, Energy, Torque, and Speed Cal's	
Rotational Effect on Zero (% of F.S.)	≤ ±0.05 for Power, Energy and Torque, none for Speed	≤ ±0.03 for Power, Energy and Torque, none for Speed
Zero Drift (% of F.S./deg. F.)	Power, Energy and Torque ≤ ±0.003; Speed= none	Power, Energy and Torque ≤ ±0.0015; Speed = none
Span Drift (% of Rdg./deg. F.)	Power and Torque ≤ ±0.003; Speed <0.0001	Power and Torque ≤ ±0.0015; Speed <0.0001
Temperature Ranges (deg. F.)	Compensated Range: +75 to +175; Usable Range: -25 to +185; Storage Range: -65 to +225	
Analog Output Signals, Auto-Scaled	Any three of Power, Energy, Torque, or Speed are simultaneously available; field changeable (Default omits Energy)	
Full Scale Power³ and Full Scale Torque³	CW = +10 Volts, CCW = -10 Volts or, CW = +5 Volts, CCW = -5 Volts; field changeable (Default = ±10V)	
Full Scale Energy³	CW = +10 Volts, CCW = -10 Volts or, CW = +5 Volts, CCW = -5 Volts; field changeable (Default = ±10V)	
Full Scale Speed³	+10 Volts or +5 Volts for CW and CCW directions; field changeable (Default = +10V)	
Nominal Overrange (% of F.S.)	50	
Resistive Load	10,000 Ohms, Minimum	
Capacitive Load	0.05 uF, Maximum	
Signal Filter Cutoff Frequency⁴	Field selectable from 0.1 to 200 Hz in eleven 1-2-5 steps using furnished software. Torque, and Speed Filters are identical and their cutoff frequencies track. Units are set to 10Hz (default) unless Purchase Order specifies another frequency.	
Output Noise (% rms of F.S.)	<0.02 at all cutoff frequencies	
System Resolution (% of F.S.)	0.02 (14 bits with 50% overrange)	
System Response	Torque is sampled @ 2kHz. Speed is the greater of 1ms and [1000/RPM] ms. Power and Energy are computed @ 50 Hz.	
RS232 Communications Port	Duplex port outputs Power, Energy, Torque and Speed with units of measure. Inputs analog output parameters, range selections, scaling and null values, cal info, units of measure, analog out trim and permits computer control of test.	
BAUD Rate	38,400	
Drivers	Short circuit (current limit) and ±15kV ESD protected.	
Maximum Cable Length	50 feet	
Supply Voltage⁵ and Total Current	11 to 24 Volts dc at 150 mA, nominal.	
Power Supply Effect	<0.002% of F.S. per Volt	
Analog Output & Cal Enable Connector Pinout	A: Power or Energy B: Speed or Energy C: Torque or Energy D: Common E: CCW Cal F: CW Cal G-K: No Connection	
Power & Com Port Connector Pinout	INPUT POWER ↔ A: + In B: Common	COM PORT ↔ A: TXD B: RXD C: Ground D: No Connection

1. Torque and Speed Ranges may be set at any value ≤ Transducer Full Scale Ratings. For example: If the set Torque range is 10,000 lbf-in, and the set Speed range is 5krpm then Power Range = 10,000*5000/63025 = 793.34 horsepower = 10V analog output. Energy Full Scale(10V out) is 99,999 counts in any units of measure. Thus, for example, it may be set to 99,999 kW-h or 9.9999 kW-h, etc. The maximum possible Energy Resolution is the Power Resolution*20ms; for the example, 0.01hp*20ms = 0.0002 hp-seconds = 4.1428E-8 kW-h which is equal to 0.14914 Joules = 0.03562 Calories = 1.3200 lbf-in, etc.

2. Assumes torque range is set to the device full scale torque rating.
 3. CW torque causes the shaft to turn CW when viewed from its driven end. CCW torque causes the opposite rotation. Energy polarity tracks torque and Energy accumulation is algebraic or net.
 4. Torque signal bandwidth upper limit is 200 Hz determined by integral Bessel response filters. The transducers' self resonant frequency is > 1 kHz.
 5. Reverse polarity protected.
 6. "deg. F." denotes "degree Fahrenheit".
 7. Specifications are subject to change without notice.

Order No #A*	MCRT® 48061P	(1-4)	N	N	E
	Model Number	Range	Performance	Foot Mount: N if no, F if yes	Energy Option: E if yes, N if no
An MCRT® 48061P(1-4)NNE is a flanged, 1,269hp, 10,000 lbf-in Horsepower/kW-h Meter with standard performance, no foot mount and Energy option.					

Standard Ratings, MCRT® 4800P Shaft End Horsepower/kW-h Meters With 200% Overload

MCRT® Model	Maximum Power (At Rated Torque & Max Speed)		Torque Rating		Speed Rating	Shaft Stiffness*	Rotating Inertia	Max Wt.
			Range	Overload				
	[hp]	[kW]	[lbf-in]		[rpm]	[lbf-in/rad]	[ozf-in s ²]	[lbs]
48001P(25-0)**	5.95	4.44	25	50	0 to ±15,000	2,150	0.034	6
48001P(5-1)	11.90	8.87	50	100	0 to ±15,000	6,030	0.034	6
48001P(1-2)	23.80	17.75	100	200	0 to ±15,000	14,700	0.034	6
48001P(2-2)	47.60	35.50	200	400	0 to ±15,000	18,900	0.034	6
48002P(5-2)	119.0	88.74	500	1,000	0 to ±15,000	57,900	0.035	7
48002P(1-3)	238.0	177.5	1,000	2,000	0 to ±15,000	70,100	0.035	7
48003P(1-3)	134.9	100.6	1,000	2,000	0 to ±8,500	197,000	0.15	11
48003P(2-3)	269.7	201.1	2,000	4,000	0 to ±8,500	260,000	0.15	11
48004P(5-3)	674.3	502.9	5,000	10,000	0 to ±8,500	580,000	0.19	14
48004P(1-4)	1,349	1,006	10,000	20,000	0 to ±8,500	605,000	0.19	14
48006P(2-4)	2,539	1,893	20,000	40,000	0 to ±8,000	1,800,000	2.3	105
48006P(4-4)	5,077	3,786	40,000	80,000	0 to ±8,000	2,700,000	2.4	105
48007P(5-4)	4,760	3,550	50,000	100,000	0 to ±6,000	5,700,000	2.8	115
48007P(1-5)	9,520	7,099	100,000	200,000	0 to ±6,000	7,100,000	3.0	115
48008P(2-5)	11,420	8,519	200,000	400,000	0 to ±3,600	29,000,000	11.0	150
48008P(375-3)	21,420	15,970	375,000	750,000	0 to ±3,600	38,000,000	11.7	150
48009P(75-4)	21,420	15,970	750,000	1,500,000	0 to ±1,800	115,000,000	205	775
48009P(15-5)	42,840	31,950	1,500,000	3,000,000	0 to ±1,800	136,000,000	212	790
48010P(3-6)	57,120	42,600	3,000,000	6,000,000	0 to ±1,200	221,000,000	567	1,455
48010P(4-6)	76,160	56,790	4,000,000	7,350,000	0 to ±1,200	227,000,000	582	1,475

*Stiffness is conservatively rated and includes the torsion section and shaft-ends.

**Code C, Enhanced Performance, is not available on this model.

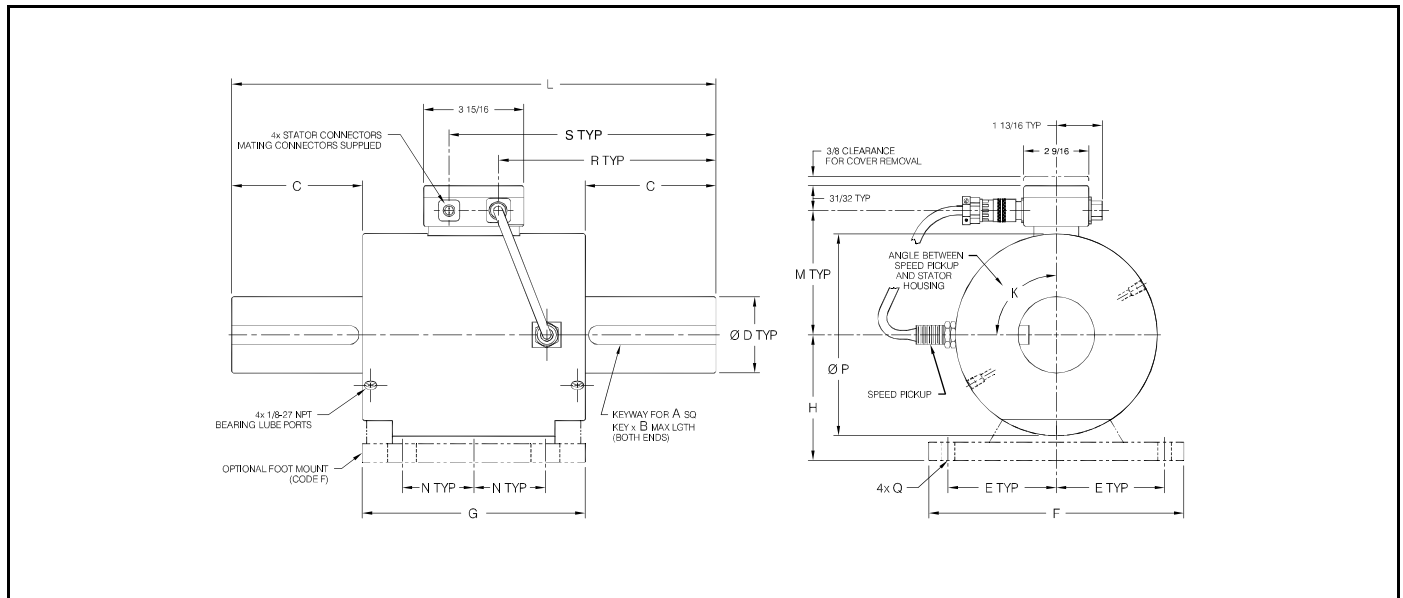

MCRT® MODEL	DIMENSIONS [inches]															
	A	B	C	D ²	E	F	G	H	L	M	N	P	K	Q	R	S
48001P	0.187	1.125	1.50	0.625	2.25	5.50	5.50	2.250	8.50	2 9/16	1 1/2	3 15/32	90°	0.406D	3 9/32	5 7/32
48002P	0.187	1.625	2.00	0.750	2.25	5.50	5.50	2.250	9.50	2 9/16	1 1/2	3 15/32	90°	0.406D	3 25/32	5 23/32
48003P	0.250	1.750	2.31	1.000	2.625	6.25	5.50	2.500	10.00	2 31/32	1 1/2	3 31/32	90°	0.406D	4 1/32	5 31/32
48004P	0.375	2.750	3.69	1.500	2.625	6.25	5.50	2.500	12.75	2 31/32	1 1/2	3 31/32	90°	0.406D	5 13/32	7 11/32
48006P	0.625	3.500	4.13	2.500	4.25	10.00	8.75	5.000	17.00	4 7/8	2 13/16	7 15/16	0°	Note 3	7 17/32	9 15/32
48007P	0.750	4.500	5.13	3.000	4.25	10.00	8.75	5.000	19.00	4 7/8	2 13/16	7 15/16	0°	Note 3	8 17/32	10 15/32
48008P	1.000	6.500	7.56	4.500	4.25	10.00	7.75	5.000	23.00	5 1/8	2 13/16	8 1/2	0°	Note 3	11 7/8	13 13/16
48009P	Note 4	8.000	9.00	7.750	7.00	15.50	18.00	8.000	36.00	7 7/8	7 7/8	3 7/8	0°	Note 3	17 1/32	18 31/32
48010P	Note 5	12	13.50	9.375	8.50	18.50	20.00	9.750	47.00	9 1/2	8 7/8	17	0°	Note 3	22 17/32	24 15/32

1. Has two 0.75" long flats spaced 90°@ both ends. 2. Tolerance on D diameter is +0.0000/-0.0005 for diameters ≤ 2.5" and +0.000/-0.001 for diameters > 2.5".
 3. Slotted 0.531 wide by 1-1/8 long. 4. Dual keyways at each end are 2" wide by 1.50" high. 5. Dual keyways at each end are 2.50" wide by 1.75" high.

Standard Ratings, MCRT® 48000P Flanged Horsepower/kW-h Meters With 200% Overload

MCRT® Model	Maximum Power (At Rated Torque & Max Speed)		Torque		Speed Rating	Shaft Stiffness*	Rotating Inertia	Max Wt.
			Range	Overload				
	[hp]	[kW]	[lbf-in]		[rpm]	[lbf-in/rad]	[ozf-in s ²]	[lbs]
48060P(1-3)	126.9	94.65	1,000	2,000	0 to ±8,000	602,000	0.6	12½
48060P(2-3)	253.9	189.3	2,000	4,000	0 to ±8,000	1,375,000	0.6	12½
48060P(4-3)	507.7	378.6	4,000	8,000	0 to ±8,000	2,640,000	0.6	12½
48061P(6-3)	761.6	567.9	6,000	12,000	0 to ±8,000	2,430,000	0.9	15½
48061P(1-4)	1,269	946.5	10,000	20,000	0 to ±8,000	2,930,000	0.9	15½
48061P(18-3)	2,285	1,704	18,000	36,000	0 to ±8,000	3,530,000	0.9	15½
48070P(24-3)	2,094	1,562	24,000	48,000	0 to ±5,500	6,800,000	8.24	51
48070P(48-3)	4,189	3,124	48,000	96,000	0 to ±5,500	12,200,000	8.27	51½
48070P(96-3)	8,378	6,247	96,000	192,000	0 to ±5,500	17,900,000	8.33	52
48080P(2-5)	11,420	8,520	200,000	400,000	0 to ±3,600	39,200,000	54.5	153
48080P(375-3)	21,420	15,970	375,000	750,000	0 to ±3,600	53,100,000	54.9	155
48090P(75-4)	21,420	15,970	750,000	1,500,000	0 to ±1,800	137,000,000	480	976
48090P(15-5)	42,840	31,950	1,500,000	3,000,000	0 to ±1,800	164,000,000	487	991
48091P(3-6)	57,120	42,590	3,000,000	6,000,000	0 to ±1,200	282,000,000	1,838	1,504
48091P(4-6)	76,160	56,800	4,000,000	7,350,000	0 to ±1,200	292,000,000	1,852	1,518

*Stiffness is conservatively rated from flange face-to-flange face.

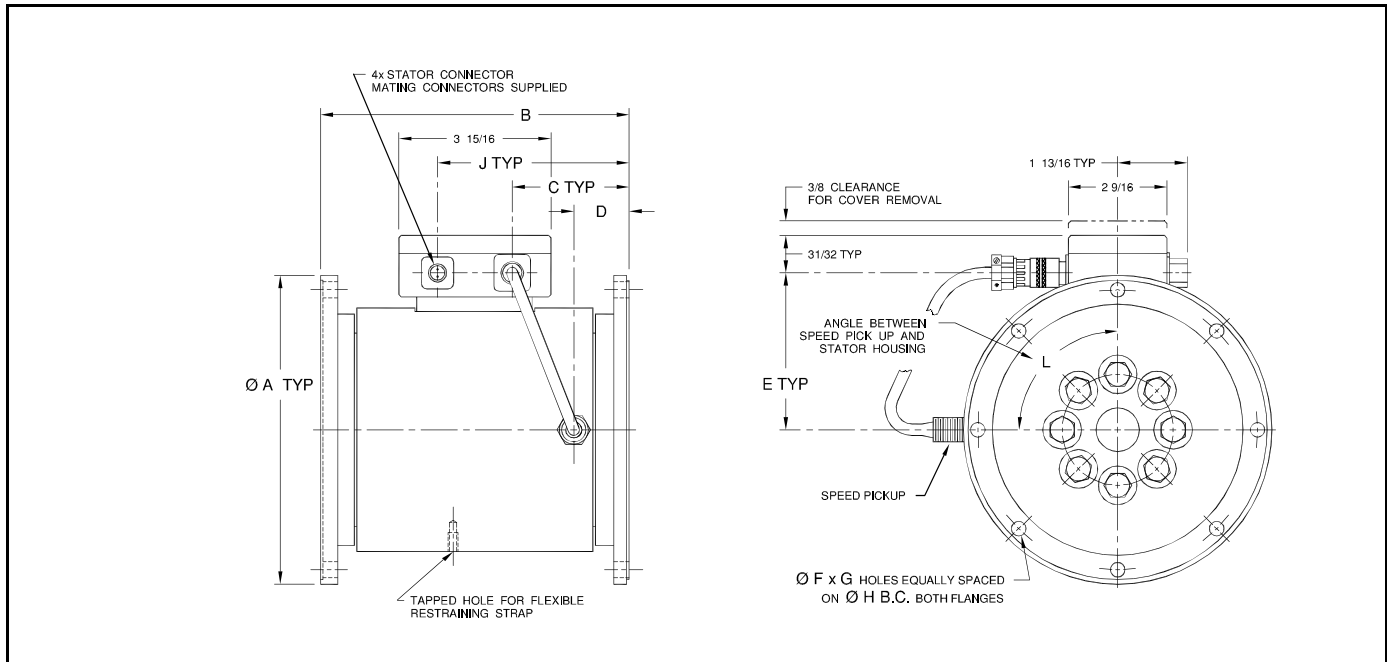

MCRT® MODEL	DIMENSIONS [inches]									
	A	B	C	D	E	F	G	H	J	L
48060P	4.250 ±0.001 (Flange faces are pilotless)	5 3/16	1 5/8	1 3/32	2 27/32	8	3/8-24UNF-2B	3.625	4 17/32	90°
48061P	4.250 ±0.001 (Flange faces are pilotless)	5 15/16	2	1 15/32	2 27/32	8	3/8-24UNF-2B	3.625	4 29/32	90°
48070P**	8 (Flange faces have male & female pilots*)	8	3 1/16	1 7/16	4 1/16	8	0.377 +0.002/-0.000	7.250	5	0°
48080P	12 (Flange faces have female pilots*)	15 1/4	7 27/32	5 5/8	5 5/32	16	0.630 +0.002/-0.000	10.375	10 3/4	0°
48090P	23 (Flange faces have female pilots*)	31	14 17/32	7 1/8	7 7/8	32	0.755 +0.002/-0.000	20.625	17 7/16	0°
48091P	30 (Flange faces have female pilots*)	37	17 17/32	9 1/8	9 1/2	32	1.005 +0.002/-0.000	27	20 7/16	0°

*Contact the factory for a print of flange details.

**MCRT® 48070P flanges mate with Spicer Series 1700/1800 drivelines.

Standard Ratings, MCRT® 49000P Shaft End Horsepower/kW-h Meters With 400% Overload

MCRT® Model	Maximum Power (At Rated Torque & Max Speed)		Torque Rating		Speed Rating	Shaft Stiffness*	Rotating Inertia	Max Wt.
			Range	Overload				
	[hp]	[kW]	[lbf-in]		[rpm]	[lbf-in/rad]	[ozf-in s ²]	[lbs]
49001P(25-0)**	5.95	4.44	25	100	0 to ±15,000	5,590	0.035	11
49001P(5-1)	11.90	8.87	50	200	0 to ±15,000	11,700	0.035	11
49001P(1-2)	23.80	17.75	100	400	0 to ±15,000	21,400	0.035	11
49002P(25-1)	59.50	44.37	250	1,000	0 to ±15,000	50,200	0.036	12
49002P(5-2)	119.0	88.74	500	2,000	0 to ±15,000	56,000	0.036	12
49003P(5-2)	79.33	59.16	500	2,000	0 to ±10,000	154,000	0.11	23
49003P(1-3)	158.7	118.3	1,000	4,000	0 to ±10,000	214,000	0.11	23
49004P(2-3)	317.3	236.6	2,000	8,000	0 to ±10,000	421,000	0.16	26
49004P(5-3)	793.3	591.6	5,000	20,000	0 to ±10,000	593,000	0.16	26
49006P(1-4)	1,269	946.5	10,000	40,000	0 to ±8,000	1,800,000	2.3	105
49006P(2-4)	2,539	1,893	20,000	80,000	0 to ±8,000	2,700,000	2.4	105
49007P(25-3)	2,380	1,775	25,000	100,000	0 to ±6,000	5,700,000	2.8	115
49007P(5-4)	4,760	3,550	50,000	200,000	0 to ±6,000	7,100,000	3.0	115
49008P(1-5)	5,712	4,259	100,000	400,000	0 to ±3,600	29,000,000	11.0	150
49008P(25-4)	14,280	10,650	250,000	750,000	0 to ±3,600	36,000,000	11.7	150
49009P(5-5)	14,280	10,650	500,000	2,000,000	0 to ± 1,800	125,000,000	207	780
49009P(1-6)	28,560	21,297	1,000,000	4,000,000	0 to ± 1,800	142,000,000	218	800
49010P(15-5)	28,560	21,297	1,500,000	6,000,000	0 to ± 1,200	221,000,000	567	1455
49010P(2-6)	38,100	28,400	2,000,000	7,350,000	0 to ± 1,200	227,000,000	582	1475

*Stiffness is conservatively rated and includes the torsion section and shaft-ends.

**Code C, Enhanced Performance, is not available on this model.

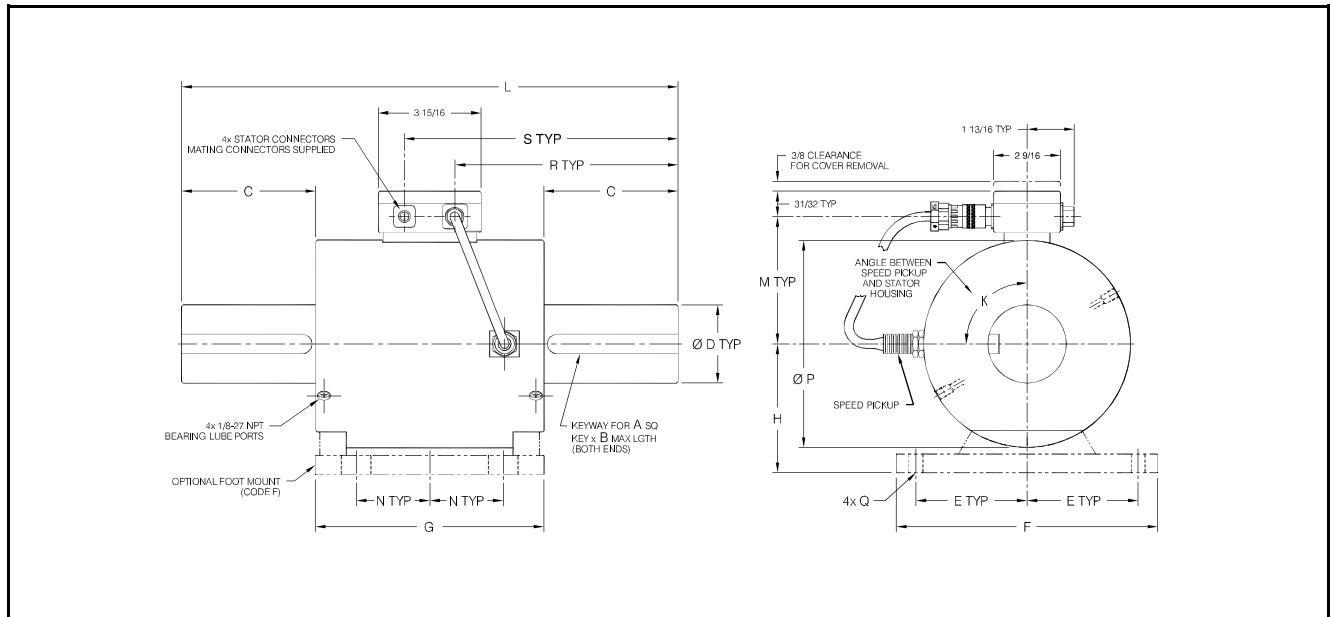

MCRT® MODEL	DIMENSIONS [inches]															
	A	B	C	D ²	E	F	G	H	L	M	N	P	K	Q	R	S
49001P	0.187	1.125	1.50	0.625	2.25	5.50	5.50	2.250	8.50	2 9/16	1 1/2	3 15/32	90°	0.406D	3 9/32	5 7/32
49002P	0.187	1.625	2.00	0.750	2.25	5.50	5.50	2.250	9.50	2 9/16	1 1/2	3 15/32	90°	0.406D	3 25/32	5 23/32
49003P	0.250	1.750	2.00	1.000	2.625	6.25	7.00	2.500	10.00	2 31/32	1 1/2	4 7/32	90°	0.406D	4 1/32	5 31/32
49004P	0.375	2.750	3.38	1.500	2.625	6.25	7.00	2.500	12.75	2 31/32	1 1/2	4 7/32	90°	0.406D	5 13/32	7 11/32
49006P	0.625	3.500	4.13	2.500	4.25	10.00	8.75	5.000	17.00	4 7/8	2 13/16	7 15/16	0°	Note 3	7 17/32	9 15/32
49007P	0.750	4.500	5.13	3.000	4.25	10.00	8.75	5.000	19.00	4 7/8	2 13/16	7 15/16	0°	Note 3	8 17/32	10 15/32
49008P	1.000	6.500	7.56	4.500	4.25	10.00	7.75	5.000	23.00	5 1/8	2 13/16	8 1/2	0°	Note 3	11 7/8	13 13/16
49009P	Note 4	8.000	9.00	7.750	7.00	15.50	18.00	8.000	36.00	7 7/8	7 7/8	13 7/8	0°	Note 3	17 1/32	18 31/32
49010P	Note 5	12	13.50	9.375	8.50	18.50	20.00	9.750	47.00	9 1/2	8 7/8	17	0°	Note 3	22 17/32	24 15/32

1. Has two 0.75" long flats spaced 90° @ both ends. 2. Tolerance on D diameter is +0.0000/-0.0005 for diameters = < 2.5" and +0.000/-0.001 for diameters > 2.5".
 3. Slotted 0.531 wide by 1-1/8 long. 4. Dual rectangular keyways at each end are 2" wide by 1.50" high. 5. Dual rectangular keyways at each end are 2.50" wide by 1.75" high.

Standard Ratings, MCRT® 49000P Flanged Horsepower/kW-h Meters With 400% Overload

MCRT® Model	Maximum Power (At Rated Torque & Max Speed)		Torque		Speed Rating	Shaft Stiffness*	Rotating Inertia	Max Wt.
	[hp]	[kW]	Range	Overload				
			[lbf-in]		[rpm]	[lbf-in/rad]	[ozf-in s ²]	[lbs]
49060P(5-2)	63.47	47.33	500	2,000	0 to ±8,000	602,000	0.6	12½
49060P(1-3)	126.93	94.65	1,000	4,000	0 to ±8,000	1,375,000	0.6	12½
49060P(2-3)	253.87	189.3	2,000	8,000	0 to ±8,000	2,640,000	0.6	12½
49061P(3-3)	380.8	284.0	3,000	12,000	0 to ±8,000	2,430,000	0.9	15½
49061P(5-3)	634.7	473.3	5,000	20,000	0 to ±8,000	2,930,000	0.9	15½
49061P(12-3)	1,523	1,136	12,000	36,000	0 to ±8,000	3,530,000	0.9	15½
49070P(12-3)	1,047	780.9	12,000	48,000	0 to ±5,500	6,800,000	8.24	51
49070P(24-3)	2,094	1,562	24,000	96,000	0 to ±5,500	12,200,000	8.27	51½
49070P(48-3)	4,189	3,124	48,000	192,000	0 to ±5,500	17,900,000	8.33	52
49080P(1-5)	5,712	4,260	100,000	400,000	0 to ±3,600	39,200,000	54.5	153
49080P(25-4)	14,280	10,650	250,000	750,000	0 to ±3,600	53,100,000	54.9	155
49090P(5-5)	14,280	10,650	500,000	2,000,000	0 to ±1,800	152,000,000	482	979
49090P(1-6)	28,560	21,300	1,000,000	4,000,000	0 to ±1,800	177,000,000	493	998
49091P(15-5)	28,560	21,300	1,500,000	6,000,000	0 to ±1,200	282,000,000	1,838	1,502
49091P(2-6)	38,100	28,400	2,000,000	7,350,000	0 to ±1,200	292,000,000	1,852	1,516

*Stiffness is conservatively rated from flange face-to-flange face.

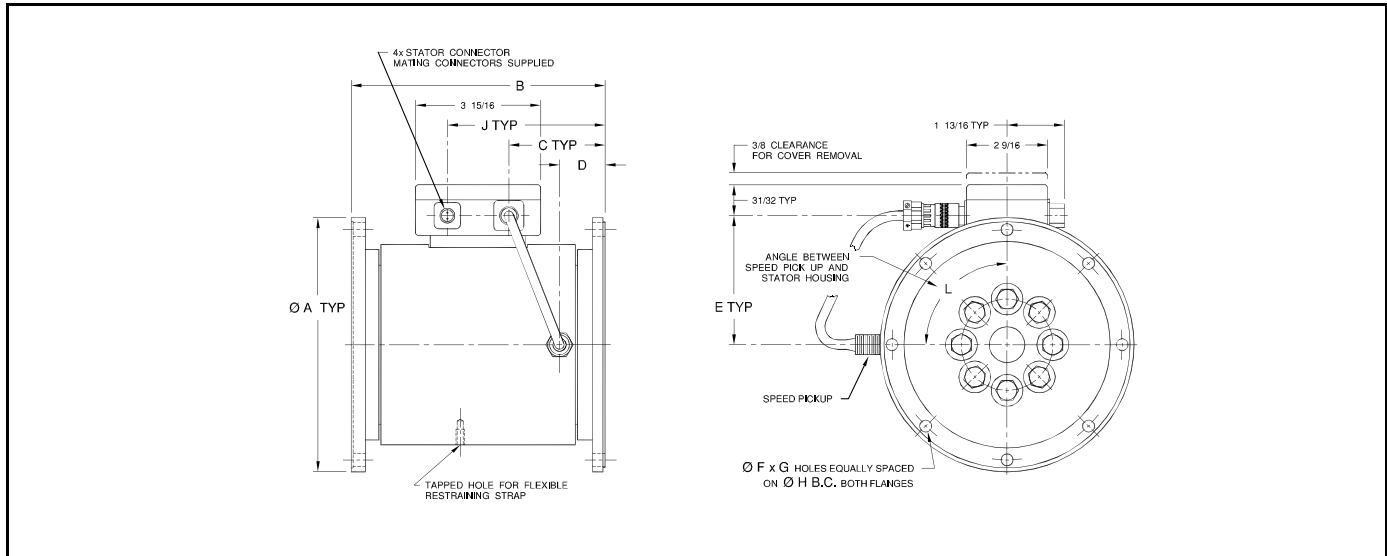

MCRT® MODEL	DIMENSIONS [inches]									
	A	B	C	D	E	F	G	H	J	L
49060P	4.250 ±0.001 (Flange faces are pilotless)	5 3/16	1 5/8	1 3/32	2 27/32	8	3/8-24UNF-2B	3.625	4 17/32	90°
49061P	4.250 ±0.001 (Flange faces are pilotless)	5 15/16	2	1 15/32	2 27/32	8	3/8-24UNF-2B	3.625	4 29/32	90°
49070P	8 (Flange faces have male & female pilots*)	8	3 1/16	1 7/16	4 1/16	8	0.377 +0.002/-0.000	7.250	5	0°
49080P	12 (Flange faces have female pilots*)	15 1/4	7 27/32	5 5/8	5 5/32	16	0.630 +0.002/-0.000	10.375	10 3/4	0°
49090P	23 (Flange faces have female pilots*)	31	14 17/32	7 1/8	7 7/8	32	0.755 +0.002/-0.000	20.625	17 7/16	0°
49091P	30 (Flange faces have female pilots*)	37	17 17/32	9 1/8	9 1/2	32	1.005 +0.002/-0.000	27	20 7/16	0°

*Contact the factory for a print of flange details.

**MCRT® 49070P flanges mate with Spicer Series 1700/1800 drivelines.

Supported Units of Measure (default units are in boldface)	
Power	hp (550ft-lbf/s), hp (metric), kW, W, ft-lbf/min, ft-lbf/s, Btu/h, Btu/min, Btu/s, ton, cal/h cal/min, cal/s
Torque	lbf-in , lbf-ft, ozf-in, ozf-ft, N-m, kN-m, N-cm, kgf-m, kgf-cm, gf-cm
Speed	rpm , rps, rph, rad/s, rad/min, rad/h, degree/min, degree/s, degree/h, grad/s
Energy (option)	kW-h , MW-h, kW-min, kW-s, W-h, W-min, W-s, kJ, J, hp-h, hp-h (metric), kcal, cal, Btu, therm, in-lbf, ft-lbf, N-m